



10-12. August 2023.

**RÉVÉSZ HUNGARIAN CROSS-COUNTRY RALLY
CHAMPIONSHIP**

SUPPLEMENTARY REGULATIONS

INDEX

Art. 1.	Introduction.....	3
Art. 1.1	Preamble	3
Art. 1.2	Length of Selective Sections	3
Art. 1.3	Overall SS distance and total distance of the itinerary.....	3
Art. 1.4	Route Conditions (Selective Stages)	3
Art. 2.	Organisation	3
Art. 2.1	Championships and titles for which the Baja counts.....	3
Art. 2.2	Approvals.....	3
Art. 2.3	Organiser's name, address, and contact details	3
Art. 2.4	Organising Committee	4
Art. 2.5	Stewards of the Meeting.....	4
Art. 2.6	Senior Officials.....	4
Art. 2.7	Location of Rally HQ and contact details	4
Art. 3.	Programme in chronological order and locations.....	5
Art. 4.	Entries	6
Art. 4.1	Closing date for entries.....	6
Art. 4.2	Entry procedure	6
Art. 4.3	Number of competitors accepted and vehicle classes	6
Art. 4.4	Entry fees/ other fees.....	6
Art. 4.5	Payment	7
Art. 4.6	Entry fee refunds	8
Art. 5.	Insurance Cover	8
Art. 6.	Advertising and Identification.....	8
Art. 6.1	Obligatory organiser's advertising.....	8
Art. 7.	Tyres.....	8
Art. 8.	Fuel.....	9
Art. 9.	Administrative checks	9
Art. 9.1	Documents to be presented:.....	9
Art. 9.2	Timetable.....	9
Art. 10.	Scrutineering, Sealing and Marking.....	9
Art. 10.1.1	Scrutineering, mandatory documents	9
Art. 10.3	Installation of the GPS Navigation and Safety Tracking System	10
Art. 11.	Other procedures and regulations	10
Art. 11.1	Ceremonial start procedures and order	10
Art. 11.2	Start Area	10
Art. 11.3	Finish procedures	10
Art. 11.4	Permitted early check-in	10
Art. 11.5	Super Special Stage / QS.....	10
Art. 11.6	Road books delivery	10
Art. 11.7	Special procedures and activities	10

Art. 11.7.1 Availability of participants.....	10
Art. 11.7.2 Classification.....	10
Art. 11.8 Official time used during the event:.....	10
Art. 11.9 Electronic start procedure at the start of a Selective Section.....	11
Art. 11.10 Service.....	11
Art. 11.10.1 Service Areas / Bivouacs.....	11
Art. 11.10.2 Flexi Service.....	11
Art. 11.10.3 Service allowed in Selective Section.....	11
Art. 11.10.4 Tyre Fitting Zone.....	11
Art. 11.10.5 Fuel and Refuelling Zone.....	11
Art. 11.11 Speed Control Zones.....	11
Art. 11.12 Shakedown.....	11
Art. 12. Identification of officials.....	12
Art. 13. Prizes.....	13
Art. 14. Final checks / Protests / Appeals.....	13
Art. 14.1 Final Checks.....	13
Art.14.2 Protest deposit.....	13
Art. 14.3 Appeal deposit.....	13

Appendix 1	Itinerary
Appendix 2	Names and photographs of the Competitors Relation officer(s) and their schedules
Appendix 3	Decals and positioning of supplementary advertising
Appendix 4	Extract from FIA Appendix L relating to overalls, helmets and any other safety requirements
Appendix 5	Instruction for the use of the GPS Tracking System
Appendix 6	Kit components for the Tracking System
Appendix 7	Items at the Organisers' discretion

Art. 1. Introduction

Name of the event: XX,HunGarian Baja 2023

Date of the event: 10-12.August 2023.

Art. 1.1 Preamble

This event will be run in compliance with the FIA International Sporting Code (ISC) including appendices, the General Prescriptions applicable for all FIA Championships, the FIA Cross-Country Rally Sporting Regulations including appendices, the WADA/NADA Codes, and the FIA Anti-Doping Regulations, as amended from time to time. The National Road Traffic Regulations of the countries the event passes shall apply. Unless provided otherwise by these Supplementary Regulations, the provisions of the above Rules and Regulations shall apply.

Any modifications, amendments and/or additions to the Rules and Regulations shall be made in the form of numbered and dated bulletins. All FIA regulations can be found at <https://www.fia.com/regulations>.

The various documents will be written in Hungarian and English. In case of any discrepancy the Hungarian text will be binding.

Art. 1.2 Length of Selective Sections

Stage 1:	221,32	km
Stage 2:	245,60	km
TOTAL	466,92	km

Art. 1.3 Overall SS distance and total distance of the itinerary

Number of Stages	2
Number of Sections	5
Number of Selective Sections	5
Total distance of the itinerary	633,37 km

Art. 1.4 Route Conditions (Selective Stages)

According to FIA CCRSR 6.6.2 - safety type B

Gravel/dirt tracks	100	%
Other surfaces	0	%

Art. 2. Organisation

Art. 2.1 Championships and titles for which the Baja counts

FIA European Cup for Cross-Country Bajas

FIA Central European Zone (CEZ) Championship

Révész Hungarian Cross-Country Rally Championship

Art. 2.2 Approvals

Visa No.: Approved on:

Art. 2.3 Organiser's name, address, and contact details

Organiser: Garilla Racing Kft. and Garzone s.r.o
Organiser's representative: Garamvölgyi Zoltán
Street/P.O. Box: Vel'koblavovská 75/39
Post code/city: 929 01 / Dunajská Streda, Slovakia
Phone: +36 30 791 4270
E-mail: info@hungarianbaja.com

Art. 2.4 Organising Committee

Organising Committee: Mr. Zoltán GARAMVÖLGYI
Mrs. Márta CAMPANARI-TALABÉR
Mr. László POLGÁR
Mrs. Zsófia CSÓVÁRI

Art. 2.5 Stewards of the Meeting

	Név
Vezető	VINOCZAI Attila
Tag	SELMECZI György
Tag	SZÁNTÓ GABRIEL

Art. 2.6 Senior Officials

	Name
Event Director:	Mr. Zoltán GARAMVÖLGYI
Clerk of the Course:	Mr. Péter FALUVÉGI
Deputy Clerk of the Course:	Mr. Dávid MAJOR
Secretary of the Event:	Ms. Julianna TÖRÖK
Chief Safety Officer:	Mr. Sándor NÉMETH
Deputy Chief Safety Officer:	Mr. Ferenc SCHEIBENHOFFER
Technical Steward	Mr. Szabolcs SOLTI
Scrutineer (Chief Scrutineer):	Mr. Tibor SZABADOS
Chief Medical Officer (CMO):	Dr. Zoltán PÁLL
Timekeeping (Chief Timekeeper):	Mr. Csaba GLÜCK - CHRONOMOTO
Competitors' Relations Officer (CRO):	Mr. István MÁTRAI
Press Officer:	Ms. Anita TÓTH
GPS	STELLA
Environmental Officer:	Mr. Péter BAKÓ

Art. 2.7 Location of Rally HQ and contact details

Name: Thury Castle
Street: Hunyadi Mátyás Tér 1.
Post code, city: 8100, Várpalota
Phone and fax: (06 88) 472 305
E-mail: info@hungarianbaja.com

Rally HQ in operation: from 10.08.2023 7:00 to 12.08.2023. 19:00

Service parc in operation: from 10.08.2023 7:00 to 12.08.2023 22:00

Digital Notice Board (DNB): Sportity, www.chronomoto.hu, www.hungarianbaja.com



On PC: https://webapp.sportity.com/channel/HGB23_MNASZ

Art. 3. Programme in chronological order and locations

Date:	Time:		Location:
01.06.2023	10:00	Publishing of the supplementary regulations	
01.06.2023	10:00	Entries open	www.hungarianbaja.com
07.06.2023	16:00	Issuing of Rally Guide	
10.07.2023	24:00	Closure date of entries at reduced fees	www.hungarianbaja.com
27.07.2023	24:00	Closure date of entries	
27.07.2023	24:00	Closing date for order of extra service in SP	info@hungarianbaja.com
27.07.2023	24:00	Closing date for shakedown registration	
02.08.2023	16:00	Publication date of entry list	Sportity, www.hungarianbaja.com
02.08.2023	10:00	Press conference before the rally	Thury Castle, Várpalota
09.08.2023	16:00-20:00	Registration, Check List and Service Plate delivery	TESCO, Várpalota
10.08.2023	07:00-18:00	Registration, Check List and Service Plate delivery	TESCO, Várpalota
10.08.2023	08:00-15:00	Administrative checks	Thury Castle, Várpalota
10.08.2023	08:00	Collection of material and documents	Thury Castle, Várpalota
10.08.2023	08:00	Collection of rally safety tracking system	Thury Castle, Várpalota
10.08.2023	08:00	Collection of navigation GPS (NAV-GPS)	Thury Castle, Várpalota
10.08.2023	08:00-16:00	Scrutineering – sealing & marking of components	TESCO, Várpalota
10.08.2023	08:00	Opening of media centre	Thury Castle, Várpalota
10.08.2023	17:00-18:00	Re-scrutineering for car which did not pass	TESCO, Várpalota
10.08.2023	11:00-14:00	Shakedown	Várpalota, according to Shakedown Roadbook
10.08.2023	15:00-18:30	Parc-Fermé	VÁRPALOTA FÓTÉR Szabadság Square
10.08.2023	18:00	Team managers and/or Drivers' briefing	
10.08.2023	18:00	Issuing of the road book (Stage 1), maps	Thury Castle, Várpalota
10.08.2023	19:00	Publication of start list for Ceremonial Start	DNB
10.08.2023	19:00	Publication of list of cars eligible to start	DNB
10.08.2023	19:00	Publication of start list for Stage 1	DNB
10.08.2023	20:00	Ceremonial Start	Thury Castle, Várpalota

11.08.2023	08:00	Start of the Rally – Stage 1, Section 1 (TC0) Prologue	Thury Castle, Várpalota
11.08.2023	09:23	Finish of Section 1 (estimated time of 1 st car)	Thury Castle, Várpalota
11.08.2023	11:30	Publication of start list for Stage 1, Section 2	DNB
11.08.2023	11:30- 12:00	Re-scrutineering, cars to re-start after retirement	TESCO, Várpalota
11.08.2023	12:00	Start of Stage 1, Section 2 (estimated time of 1 st car)	Thury Castle, Várpalota
11.08.2023	20:13	Finish of Stage 1 (estimated time of 1 st car)	Thury Castle, Várpalota
11.08.2023	22:30	Publication of start list for Stage 2	DNB
12.08.2023	09:00	Re-scrutineering, cars to re-start after retirement	TESCO, Várpalota
12.08.2023	10:00	Start Stage 2 (estimated time of 1 st car)	Thury Castle, Várpalota
12.08.2023	17:13	Finish of Stage 2 (estimated time of 1 st car)	Thury Castle, Várpalota
12.08.2023	17:30	Final scrutineering; Immediate after arrival in the finish (following the marshals' instructions)	MÁRIA GUMI, Várpalota
12.08.2023	18:30	Publication of Provisional Classification	DNB
12.08.2023	19:00	Publication of Final Classification; After the Stewards have declared the Classification final.	DNB
12.08.2023	19:00	Podiums Ceremony / Prize-giving	Thury Castle, Várpalota

Art. 4. Entries

Art. 4.1 Closing date for entries

See programme in chronological order (SR Art. 3) and FIA CCRSR Art. 17

Art. 4.2 Entry procedure

Entries must be submitted in accordance with the FIA CCRSR Art. 16 – Art. 18.

See also FIA International Sporting Code Art. 3.8 – Art. 3.14

Entries can be submitted on the Organisers' website www.hungarianbaja.com. The entry fee must be credited in full to the organiser's bank account.

In addition to the completed application, it is necessary to send scan copies by e-mail to julianna@hungarianbaja.com of:

- proof of payment of the entry fee
- Competitors licence
- Drivers and co-drivers ASN licences
- Valid Compulsory Liability Insurance of the racing vehicle
- Certificate of vehicle ownership or written authorisation from the owner.

According to the FIA International Sporting Code, foreign competitors/drivers must have their ASN's permission, which should be attached to the entry form (ASN's stamp on the entry, or the ASN's written permission to take part in the competition, or the licences copies with the described permissions in them)

Art. 4.3 Number of competitors accepted and vehicle classes

Art. 4.3.1 The number of competitors must be a minimum of 30 vehicles

Art. 4.3.2 Eligible cars

T1, T2, T3, T4, T4Nat, T5, TH-C, TH-M

Art. 4.4 Entry fees/ other fees

4.4.1. Entry fee: T1, T2, T3, T4, T4Nat, TH-C, TH-M

Prices are valid for foreign license holders

With organiser's optional advertising:

EUR 820 **payment transferred** up to entry closing date with reduced entry fee: **10.07.2023**
EUR 985 up to entry closing date: 27.07.2023
EUR 2200 **FIA Baja EU Cup + CEZ + Hun. Champ. up to entry closing date: 27.07.2023**

Without organiser's optional advertising:

EUR 1315 **payment transferred** up to entry closing date with reduced entry fee: 10.07.2023
EUR 1580 up to entry closing date: 27.07.2023

FIA Baja EU Cup + CEZ + Hun. Champ.

EUR 2200 **payment transferred** up to entry closing date with reduced entry fee: **10.07.2023**
EUR 2650 up to entry closing date: 27.07.2023

Entry fee: T5 Trucks 2200 €

Team Registration: 100 €

The entry fee includes:

- Additional compulsory liability insurance
- 1 pc. Basic service plate
- Basic service area per vehicle (50m²)
- GPS rental fee

4.4.2. To be paid on site!

Deposit for GPS navigation and safety tracking system: 100 €

GPS navigation and safety tracking system's **installation kit** 80 €

Teams with more vehicles wanting to enter to the service parc, must purchase an additional 50m² service area. For a Service area up to 50m², max 2 entry permission (service plate) can be purchased!

Extra service areas requested and the number of extra service plates has to be indicated on the Entry Form

4.4.3. Other Fees

- additional permission to the service parc (service plate): 100 €
- Additional service area (50m²): 60 €
- Trailers, Motorhomes, Promotion Vehicles: 60 €
- Waterproof Road Book 100 €
- Shakedown 200 €

The Entry Form will be accepted only with the proof of payment of the entry fee.

Art. 4.5 Payment

All entry fees must be transferred to the following bank account (EUR):

Slovenská Sporiteľna, a.s., Slovakia Garzone s.r.o
Bank Account holder

SK2609000000005063476359
IBAN

GIBASKBX
SWIFT / BIC

Please note: Hungarian Baja 2023, and the full name of the driver.

With signing the Entry Form, competitors agree, the GPS system operators to give their data to the organizer, event's officials.

Art. 4.6 Entry fee refunds

The entry fee shall be refunded in full

- if the event does not take place
- to teams whose entry application is rejected

The organiser may partially refund entry fees, if a competitor cannot take part in the event due to a duly proved case of force majeure.

Art. 5. Insurance Cover

Name of the insurance company: SRC SPECIAL RISK CONSORTIUM GMBH, Kuniberts kloster 7-9, D 50668 KÖLN.

The limit of the responsibility is 3.000.000 Eur.

- In case of an accident leading to insurance event, the competitor or his representative must make a written statement to the Clerk of the Course, the Competitors Relations Officer, or directly to the Organizer, within 24 hours. This statement must mention the accident circumstances, the names and addresses of the casualties, as well as contact details of the witnesses.
- Competitors are reminded that only damage caused by the organizers and named drivers are covered by the Organization's insurance policy. Loss or injury that may be suffered by the drivers themselves or participating vehicles is EXCLUDED.
- Irrespective of this Third Party insurance, entrants and drivers are free to take out the policies they deem fit on their own account and at their own discretion.
- Service vehicles, including those displaying the plates supplied by the Organization, shall under no circumstances be deemed participating vehicles. They are therefore not covered by the Organization's insurance policy and responsibility for them lies solely with their owners.
- The insurance cover will come into effect from the administrative checking and scrutineering for the Event and end upon the expiry of one of the following time limits, whichever is the later:
 - time limit for protests or appeals or the end of any hearing by the Stewards;
 - end of the administrative checking and postevent scrutineering;
 - end of the prize-giving.

The Organization refuses all responsibility stemming from the consequences of infractions of the law, regulations and decrees of Hungary, committed by Competitors or their service crew, which must be exclusively borne by them.

Art. 6. Advertising and Identification

See Appendix 4 of these SR "Decals and positioning of supplementary advertising".

Art. 6.1 Obligatory organiser's advertising

Rally plate: 42x21 cm

Competition number size: 67 x 22 cm

Windshield start number: 20x10 cm

Windshield advertising sticker: 25x10 cm

TBA in a Bulletin

Art. 6.2 Optional organiser's advertising

Advertising decal: 50x50cm

The organiser will provide each crew with the number identification (67x22cm), rally plate, advertising stickers, which must be affixed to their car in the stated positions prior to scrutineering.

Without optional advertising the Entry Fee is +60%. **It is not allowed to cut the panels.**

Art. 7. Tyres

See Art. 10 of the FIA CCRSR. and Art. 10 of Appendix V2 of the FIA CCRSR

Art. 8. Fuel

Refuelling is permitted only in commercial fuel stations using fuel on sale to the public. Only the crew may carry out this procedure. Refuelling stations authorised will be indicated in the Road Book with "FUEL STATION". All type of fuel must follow Appendix J Art. 252.9. (Art. 57 of the FIA CCRSR).

Art. 9. Administrative checks

Before Administrative Check, each team must Register (Várpalota Tesco, Fehérvári str.17), where the Checklist and Service Plates will be provided.

Art. 9.1 Documents to be presented:

To minimize the time required for administrative check, please make a photo or scan copies of the documents required at the administrative, and send them to the following email address: julianna@hungarianbaja.com.

Make sure to bring and present the following documents:

- Competitors' licence
- Driver's and co-driver's competition licences
- Driver's and co-driver's ID cards/passports
- Driver's and co-driver's valid driving licences valid for the vehicle entered
- ASN authorisation for foreign competitors (if required)
- Completion of all details on the entry form
- Car registration papers
- Car insurance cover
- FIA Technical Passport (if applicable) or ASN Passport for competitors with foreign licences
- FIA homologation form for T2 category
- Authorization from the owner of the vehicle in case is other than the driver or navigator

Art. 9.2 Timetable

See programme (SR Art. 3)

Individual times for each competitor for the administrative checks will be published on Sportity and www.hungarianbaja.com in a Bulletin.

Before the administrative, the GPS navigation and safety tracking system has to be collected.

Art. 10. Scrutineering, Sealing and Marking

10.1. Scrutineering, venue and time:

Location: VÁRPALOTA TESCO, Fehérvári str.17.

Time: 10.08.2023. 08:00-16:00 according to scheduled time for each crew!

Cars may be presented at scrutineering by a representative of the team.

Art. 10.1.1 Scrutineering, mandatory documents

- Cars' complete original FIA Homologation Document (if applicable)
- FIA / ASN Technical Passport (if applicable)
- Fully filled Scrutineering Sheet, provided by the Organizer

Art. 10.1.2 Time, schedule

See programme (SR Art. 3)

Individual times for each competitor for the Technical Scrutineering will be published on Sportity and www.hungarianbaja.com in a Bulletin.

After passing the Scrutineering, competitors must put their vehicles in the Park Fermé. Time: 15:00-18:30

Art. 10.2 Requirements at technical scrutineering:

- Vehicles must be presented with all start numbers, rally plates, and advertisements fixed properly on the designated place.
- GPS navigation and safety tracking system installed and operable
- Scrutineering Sheet- filled up
- Homologation Form, valid Technical Passport
- All items of clothing including helmets and FHR (Front Head Restraint) intended to be used, e.g. HANS devices, must be presented
- Technically corresponding and approved size fire extinguisher properly fitted in the car
- Warning triangle, medical kit. The new medical kit...etc. is not mandatory (Art.CCRSR APPIII.
1. Medical kit, 2. Survival kit)

Art. 10.3 Installation of the GPS Navigation and Safety Tracking System

All vehicles must **only** be fitted with the GPS Navigation and Safety Tracking System provided by the Organiser. You can collect them just before the Administrative check, the associated installation kit can be purchased.

The instruction for the use of the Tracking System is in the Appendix 5. of these Supplementary Regulation.

Returning the GPS Navigation and Safety Tracking System at the Parc Fermé, to the STELLA crew.

Art. 11. Other procedures and regulations

Art. 11.1 Ceremonial start procedures and order

On Thursday evening, everyone will exit from the Parc Fermé to the Starting Ceremony, based on the issued Start List. It is mandatory to return to the Parc Fermé afterwards.

Art. 11.2 Start Area

See programme SR Art.3

Art. 11.3 Finish procedures

At the end of Stage2, the crews must place the vehicles in Parc Fermé, located in Várpalota Főter, Szabadság square, according time schedule of the event on Saturday, 12th August.

Art. 11.4 Permitted early check-in

Early-check in is allowed at TC2C and TC4A

Art. 11.6 Road books delivery

The Organiser will issue coloured, printed Road Book as follows (See also program (SR Art. 3):

- At Administrative Checks: Road Book for Shakedown Stage.
- At Briefing: Road Book for Stage1: 18:00
- Entering Parc Fermé at the end of Stage1: Road Book for Stage2

Art. 11.7 Special procedures and activities

Art. 11.7.1 Availability of participants

Participants who park their vehicles in the Parc Fermé upon passing the finish line, must remain available by phone (mobile) until the final classification have been posted.

Art. 11.7.2 Classification

The final classification will be published on the website on the Digital Notice Board: Sortity, www.hungarianbaja.com and www.chronomoto.hu

Art. 11.8 Official time used during the event:

GPS time

Art. 11.9 Electronic start procedure at the start of a Selective Section

The start of the selective section is happening based on an electric clock and lamp, connected to a false start alert system.

When the car arrives at the start line, the front of the car should be positioned behind a stick placed by the marshal to define the exact start position. One minute before the start time, but not before the car has stopped in its exact position, the marshal shall remove the stick and the crew shall refer to the automatic countdown clock. Any subsequent change of the car's position until its start time is not permitted and will be reported to the Stewards.

Art. 11.10 Service

Using a min 5x4m protector groundsheet under the racing vehicles is mandatory. 1pc at least 4kg validated manual fire extinguisher is mandatory. Each service team has to ensure that after carrying out their activities on the site, they do not leave any pollutants. They will be checked by the scrutineers, and not complying will entail a 50.000HUF fine.

The Organizer calls the attention of the participants, that the Service Park is not guarded at night time!

Art. 11.10.1 Service Areas / Bivouacs

Várpalota, Fehérvári str. 17.

Access will be permitted to the Servicepark only showing the Service Plates provided by the Organizer at the Registration. Accompanying team cars can enter only by purchasing a 100€ sticker at the Registration or Administrative Checks(1 service plate/team is provided by the Organizer).

Tampering with or falsification of these plates will lead to disqualification of the team to which these service vehicles belong, on the decision of the Stewards. Plates will be placed in a visible area inside of the front windscreen of the vehicle.

The maximum speed allowed in the service park is 30 km/h in according with Art.51.3.of the 2022 FIA CCRSR. In case of a violation of this regulation by any vehicle/team member related to a competitor, the competitor will be penalized with 10 seconds per km/h over the speed limit.

Art. 11.10.2 Flexi Service:

Not applicable

Art. 11.10.3 Service allowed in Selective Section

Forbidden

Art. 11.10.4 Tyre Fitting Zone

In Servicepark only.

Art. 11.10.5 Fuel and Refuelling Zone

Refuelling is permitted only in commercial fuel stations using fuel on sale to the public. Only the crew may carry out this procedure. Refuelling stations authorised will be indicated in the Road Book with "FUEL STATION".

On SS1A, SS1B, SS2A, SS2B, SS3A, SS3B, SS4A, SS4B will be a Neutralization Zone for all Competitors and a separate Remote Refuelling Zone (RRZ) for Motor, Quad, and NATIONAL T3 & T4 vehicles only.

Art. 11.11 Speed Control Zones

According to Roadbook

Art. 11.12 Shakedown

01. 06. 2022. Friday	Opening date for shakedown's entries
25. 07. 2022 Thursday	Closing date for shakedown's entries
04. 08. 2022 Thursday 08.00-19.00	Delivery Shakedown's materials (Identification plates – Road Book

Friday 05 August 09:00 to 13:00 Shakedown Length: 4km

ENTRY PROCEDURE: Anybody wishing to perform the Shakedown must register on the Entry Form, or via email to the Secretariat of the Event: info@hungarianbaja.com

REGISTRATION FEE FOR SHAKEDOWN

Fee received from 1. June to 27. July.	
Entrant (2 hours)	€ 200,00

The price includes:

- VAT 27%
- Insurance
- SHAKEDOWN Road Book
- SHAKEDOWN sticker
- Rescue and Medical preparedness

CONDITIONS TO PARTICIPATE:

- Driver and co-driver must be registered in the Entry Form of HunGarian Baja 2023;
- The vehicle must be the one indicated in the entry form of HunGarian Baja 2023;
- The vehicles must have passed the pre-event scrutineering
- The shakedown fee must be paid;

SHAKEDOWN'S PLATES

To participate at the Shakedown, all identification and advertising panels received at the administrative check, including the Shakedown sticker (1 strip 25 cm x 10 cm to the centre top of the windscreen) must be affixed to the racing vehicle.

SERVICE AREA

Close to the Shakedown zone, the Organiser will provide an area where it will be possible to service on the race vehicles.

RUNNING OF THE SHAKEDOWN

Inside the race car, there will be both competitors registered at the HunGarian Baja 2023 and must wear FIA Homologated clothing and equipment, in accordance with Appendix L.

Vehicles will start with an interval of 2 (two) minutes: the starting order will be based on their arrival at the preset zone and they can make as many laps as they wish in two hours.

After the Shakedown, participants must put their cars in the Park Fermé 15:00-18:30 10.08.2023.

Art. 11.13 Onboard Cameras

The request for the On-Board cameras must be indicated on the Entry Form and installed prior to the Technical Scrutineering, where it will be checked and identified by an adhesive decal provided by the Organiser (see Art.11.2 of the FIA CCRSR).

Art. 11.14 Briefing

The briefing for competitors and Road Book delivery will take place according the program (see SR Art.3). The participation of at least one crew member is compulsory.

Art. 11.15 Reconnaissance

As from the publication of the Supplementary Regulations, the presence of a competitor, or anyone connected with a competitor, on any part of the itinerary of the event is prohibited. (Art. 28 of the 2023 FIA CCR SR)

Art. 12. Identification of officials

Competitors Relation Officer *"CRO" Pink armband*
Scrutineers *"ATB" Blue tabard or shirt*

Post Chiefs: "VEZETŐBÍRÓ" Red tabard
Special Stage Commanders: "VEZETŐBÍRÓ" Red tabard
Marshals: "SAFETY" / "SPORTBÍRÓ" Yellow or White tabard
Timekeepers: "CHRONOMOTO" Black shirt

Art. 13. Prizes

Overall classification: 1-3 places: Cups
Group Classification: 1-3 places: Cups

Prizes only will be awarded to crews present at the prize-giving ceremony. Absent crews will lose their right to get the prizes.

Vehicles entered in a class with less than 6 entrants will be competing only for the general classification and respective group classification.

Art. 14. Final checks / Protests / Appeals

Art. 14.1 Final Checks

Time: see programme (SR. Art. 3)
Location: Mária Gumi

Any teams required to undergo final checks must immediately follow the instruction of the marshals in charge, even if this prevents them from proceeding to one or more time controls (TC). The complete original FIA homologation form, the FIA Passport and other necessary certifications must be available for final checks.

Art.14.2 Protest deposit

General: 350 €
Technical: 350 €

Art. 14.3 Appeal deposit

According to General Prescription.

Appendix 1 – Itinerary



XX. HUNGARIAN BAJA

CAR

Stage 1		2023.08.11. FRIDAY / PÉNTEK						
Sunrise	5:29						20:17	Sunset
IE/TC	Location	SS Maximum Time	SS Km	Liasion Km	Total Km	Target Time	1st vehicle Due	
TC0A	VÁRPALOTA Parc Ferme OUT						8:00	
TC0B	Várpalota			3,33	3,33	0:10	8:10	
DSS P	PROLOGUE START					0:05	8:15	
ASS P	PROLOGUE FINISH	0:30	9,47		12,80	(0:08)	(8:23)	
	Várpalota					(Expected time of arrival)		
TC0C	Service IN (FIA Tire marking & Technical Zone)			6,73	19,53	0:10	8:33	
SERVICE A								
TC0D	Service OUT (FIA Tire marking)			0,83	20,36	0:30	9:03	
<i>Refueling, Petrol Station,</i>								
TC0E	Regrouping IN			0,51	20,87	0:20	9:23	
REGROUPING / START POSITION CHOOSING for LEG1 Section 2 - ONLY for the TOP 10 on Podium (Sportity)							11:00	
TC0F	Regrouping OUT						12:00	
TC1	Várpalota			2,76	23,63	0:10	12:10	
DSS 1A	START					0:05	12:15	
ASS 1A	FINISH	1:30	52,67		76,30	(0:42)	(12:57)	
	Gyulaifirátót					(Expected time of arrival)		
Neutralization zone								
	Gyulaifirátót			1,38	77,68	0:15	13:12	
DSS 1B	START						13:12	
ASS 1B	FINISH	1:30	57,99		135,67	(0:46)	(13:58)	
	Újmajor					(Expected time of arrival)		
<i>Refueling, Petrol Station,</i>								
TC1A	Service IN (FIA Tire marking & Technical Zone)			31,50	167,17	0:50	14:48	
SERVICE / SZERVIZ B								
TC1B	Service OUT (FIA Tire marking)			0,83	168,00	0:40	15:28	
TC1C	Regrouping IN			0,51	168,51	0:05	15:33	
REGROUPING								
TC1D	Regrouping OUT						16:00	
TC2	Várpalota			2,76	171,27	0:10	16:10	
DSS 2A	START					0:05	16:15	
ASS 2A	FINISH	1:30	52,67		223,94	(0:42)	(16:57)	
	Gyulaifirátót					(Expected time of arrival)		
Neutralization zone								
	Gyulaifirátót			1,38	225,32	0:15	17:12	
DSS 2B	START						17:12	
ASS 2B	FINISH	1:30	57,99		283,31	(0:46)	(17:58)	
	Újmajor					(Expected time of arrival)		
<i>Refueling, Petrol Station,</i>								
TC2A	Service IN (FIA Tire marking & Technical Zone)			31,50	314,81	0:50	18:48	
SERVICE / SZERVIZ C								
TC2B	Service OUT (FIA Tire marking)			0,83	315,64	1:20	20:08	
TC2C	Parc Ferme IN / Early Check-IN is Authorised			0,51	316,15	0:05	20:13	
Day Total			221,32	85,36	316,15			
			70,00%	27,00%	100%			



XX. HUNGARIAN BAJA

CAR

Stage 2		2023.08.12. SATURDAY / SZOMBAT						
Sunrise 5:30							20:15	Sunset
IE/TC SS	Location	SS Maximum Time	SS Km	Liasion Km	Total Km	Target Time	1st vehicle Due	
TC2D	Parc Fermé OUT						10:00	
Refueling, Petrol Station,								
TC3	Újmajor			29,81	29,81	0:45	10:45	
DSS 3A	START					0:05	10:50	
ASS 3A	FINISH	1:30	58,30		88,11	(0:47)	(11:37)	
Gyulafirátót <i>(Expected time of arrival)</i>								
Neutralization zone								
Gyulafirátót				1,38	89,49	0:15	11:52	
DSS 3B	START						11:52	
ASS 3B	FINISH	1:40	64,50		153,99	(0:51)	(12:43)	
Várpalota <i>(Expected time of arrival)</i>								
TC3A	Service IN (FIA Tire marking & Technical Zone)			3,95	157,94	0:10	12:53	
SERVICE / SZERVIZ D								
TC3B	Service OUT (FIA Tire marking)			0,83	158,77	0:40	13:33	
Refueling, Petrol Station,								
TC3C	Regrouping IN			0,51	159,28	0:20	13:53	
REGROUPING								
TC3D	Regrouping OUT						14:15	
TC4	Újmajor			29,81	189,09	0:45	15:00	
DSS 4A	START					0:05	15:05	
ASS 4A	FINISH	1:30	58,30		247,39	(0:47)	(15:52)	
Gyulafirátót <i>(Expected time of arrival)</i>								
Neutralization zone								
Gyulafirátót				1,38	248,77	0:15	16:07	
DSS 4B	START						16:07	
ASS 4B	FINISH	1:40	64,50		313,27	(0:51)	(16:58)	
Várpalota <i>(Expected time of arrival)</i>								
TC4A	Parc Ferme IN / Early Check-IN is Authorised			3,95	317,22	0:15	17:13	
Day Total			245,60	71,62	317,22			
			77,42%	22,58%	100%			

Section 4

Section 5

	SS km	Liasion km	Total km
Rally Total	466,92	156,98	633,37
	73,72%	24,78%	100%

Appendix 2 - Name and photo of the Competitors Relation officer and schedule



(ENG / DEU / HUN)
Mr. István MÁTRAI
+36 20 417 6249

Estimated working plan:

Thursday 10. August	Admin check Scrutineering Briefing / Start TC / Start Ceremony	08:00 – 15:00 08:00 – 18:00 19:00 – 21:00
Friday 11. August	Parc Fermé / Service area	08:30 – 22:30
Saturday 12. August	Parc Fermé / Service area Finish Ceremony	08:30 – 18:00 19:00

Appendix 3 – Decals and positioning of supplementary advertising

List and positioning of advertising in the Bulletin!



**Mandatory
stickers
placement.**

ADVERTISING

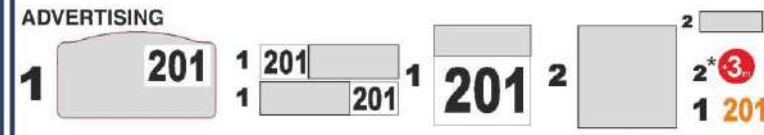

* According FIA CCR GP

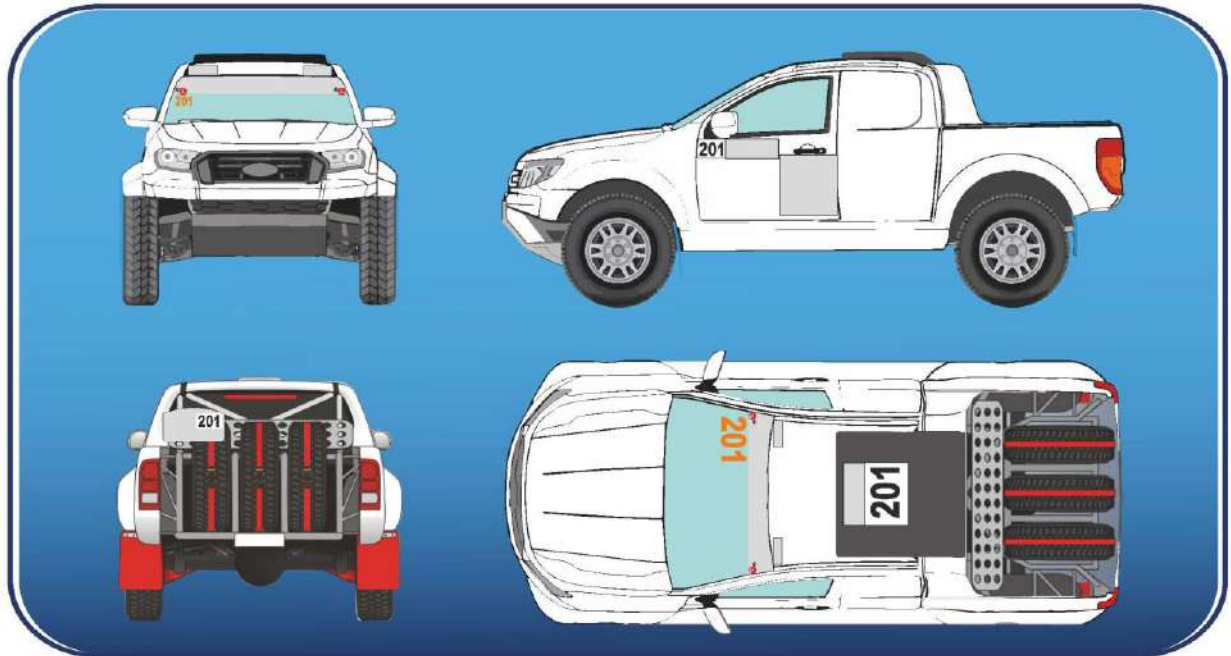

Matricák felhelyezése / Positioning of the stickers:

1. Rajtszám / Competition nr.: 67x22cm
2. Reklámtábla / Advertizing decal : 30x30cm
3. Szélvédő matrica / Windshield advertising sticker: 25x10 cm
4. +3 perc / +3 minute
5. Szélvédő Rajtszám / Windshield start number: 20x10 cm
6. Tetőrajtszám / Roof start number: 50x50cm
7. Rallytábla / Rallyplate: 21x10cm



Appendix 4 – Extracts from FIA ISC Appendix L relating to overalls, helmets and any other safety requirements

All competitors are reminded of Appendix L of the FIA International Sporting Code, in particular its Chapter III - Drivers' Equipment.

Helmets (Appendix L, Chapter III, Art. 1)

All crews must wear crash helmets homologated to one of the FIA standards listed in Appendix L.

Frontal Head Restraint (FHR, Appendix L, Chapter III, Art. 3)

All crews must use FIA approved FHR systems homologated to FIA standard 8858.

Approved FHRs, anchorages and tethers are listed in Technical List N° 29.

See also helmet compatibility chart in Appendix L, Chapter III, Art. 3.3.

Flame-resistant clothing (Appendix L, Chapter III, Art. 2)

All drivers and co-drivers must wear overalls as well as gloves (optional for co-drivers), long underwear, a balaclava, socks and shoes homologated to the FIA 8856-2000 standard, technical List N°27, or 8856-2018, technical List N° 74 (Mandatory for all FIA priority drivers and their co-driver). Please pay special attention to the prescriptions of Art. 2 concerning embroidery and printing on flame-resistant clothing (manufacturer certificates etc.) as well as concerning the correct wearing of the clothing elements! See also FIA Cross-Country Rally Sporting Regulations Article 47.1.

Biometric Devices (Appendix L, Chapter III, Art. 2.1)

Drivers may wear a device to collect biometric data during racing.

- If the biometric device is integrated into a protective garment homologated to FIA Standard 8856, the garment shall be homologated to FIA Standards 8856 and 8868-2018.
- If the biometric device is a stand-alone device, then the device must be homologated to FIA Standard 8868-2018 only. This device must be worn in addition to the garment homologated to FIA Standard 8856.

Wearing of jewellery (Appendix L, Chapter III, Art. 5)

The wearing of jewellery in the form of body piercing or metal neck chains is prohibited during the competition and may therefore be checked before the start.

MEDICAL AND SURVIVAL KIT (Appendix IV of the Cross-County Rally Sporting Regulations)

A sealed and valid Medical kit in accordance with the Specification for Cross Country Rallies and Bajas (Technical List n°83) must be placed inside the cockpit. The minimum weight must comply with Technical List n°83.

RELATED LINKS:

FIA International Sporting Code and appendices:

<https://www.fia.com/regulation/category/123>

FIA Technical Lists:

<https://www.fia.com/regulation/category/761>



MAIN SCREEN

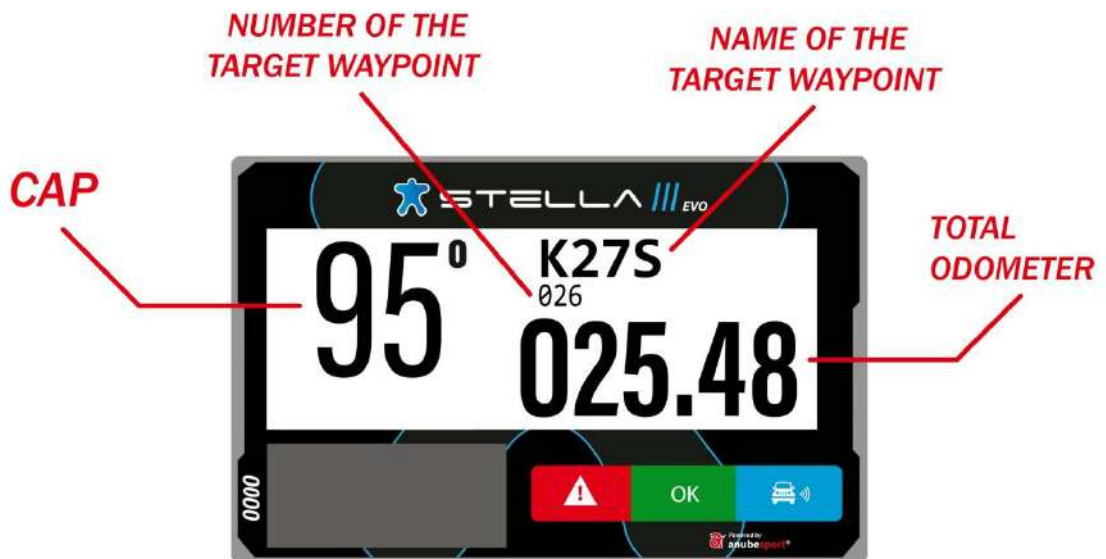

WAYPOINT PROXIMITY



SPEED ZONE

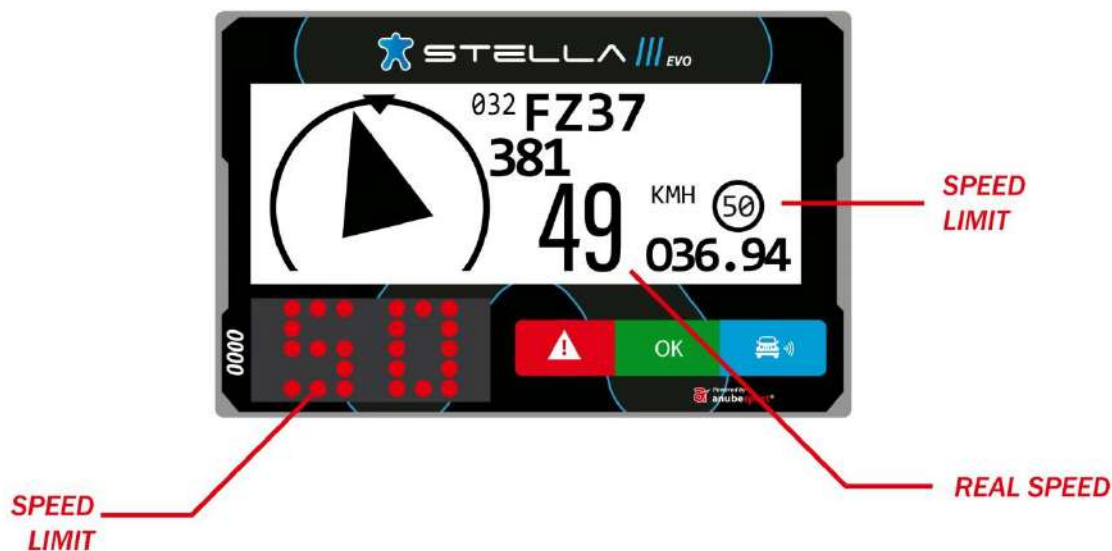

REQUEST MEDICAL ATTENTION IMMEDIATELY



SOS

1 sec.



CAUTION VEHICLE STATIONARY



3 sec.
BREAKDOWN



DANGER 3 !!!



Notification 300m before an area marked in the roadbook as "Danger 3"

OVERTAKING / BLUE FLAG

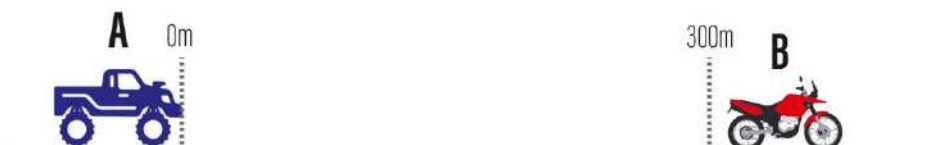

OVERTAKING / BLUE FLAG



STEADY



FLASHING



OVERTAKING / BLUE FLAG



FREE TO OVERTAKE



STEADY

PRESS THE BLUE BUTTON TO CONFIRM



SPEED LIMIT



SPEED LIMIT

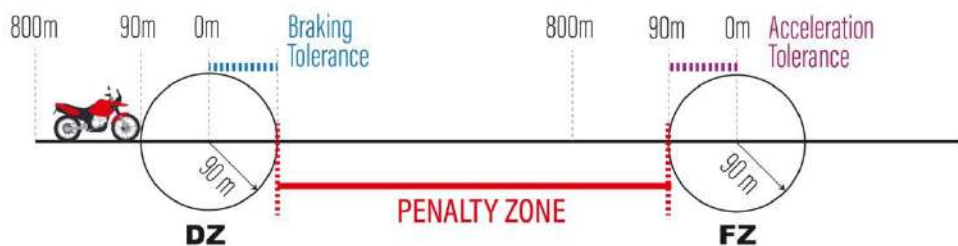

SPEED LIMIT



RED STEADY Inside of speed zone
RED FLASHING Overspeed

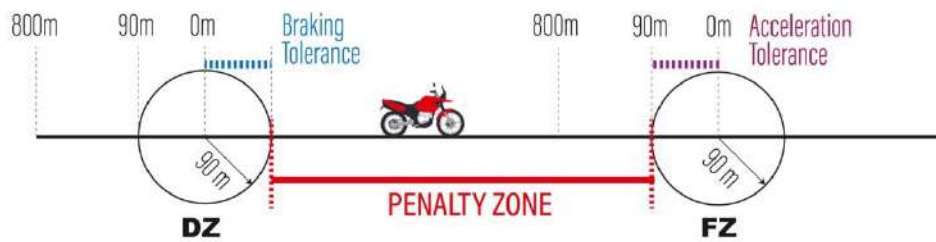

SPEED LIMIT



OFF end of speed zone

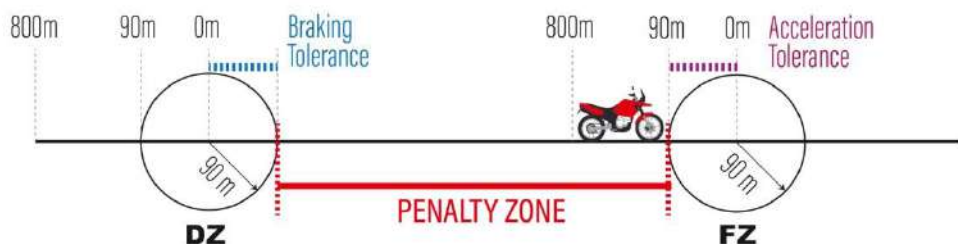

NEUTRALIZATION ZONE



NEUTRALIZATION ZONE

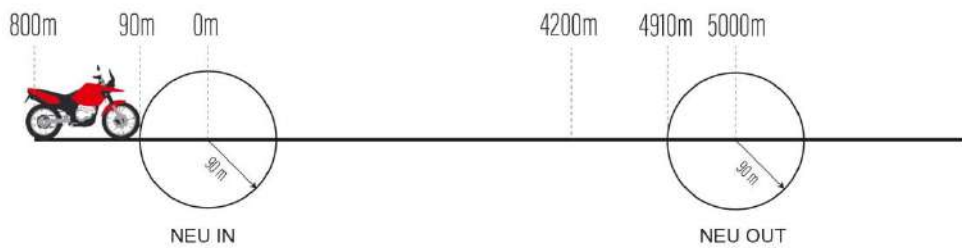

NEUTRALIZATION ZONE

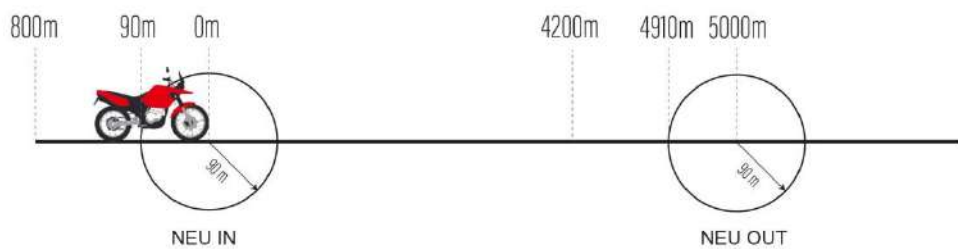

NEUTRALIZATION ZONE

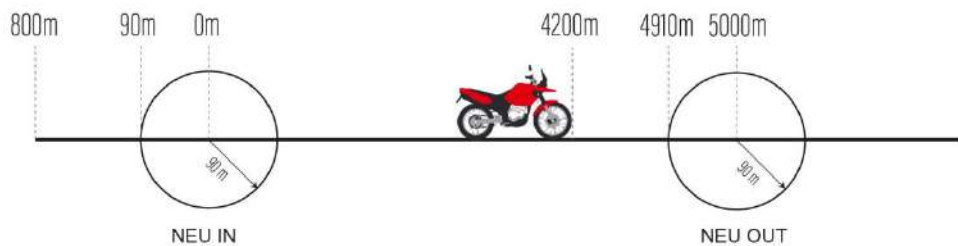

NEUTRALIZATION ZONE

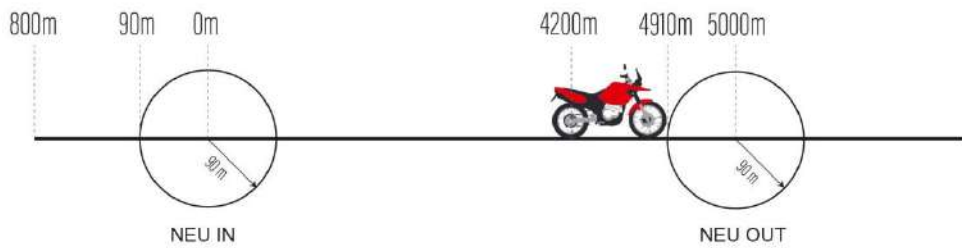

NEUTRALIZATION ZONE

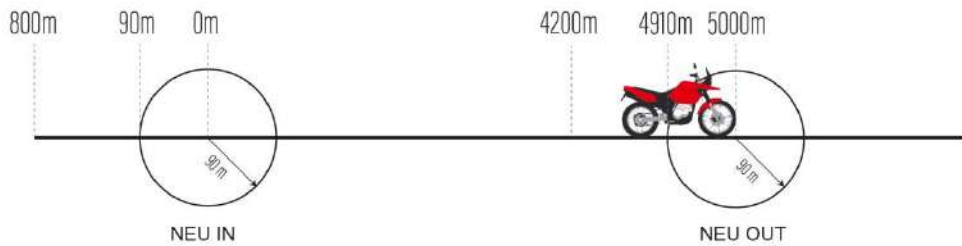

MESSAGES

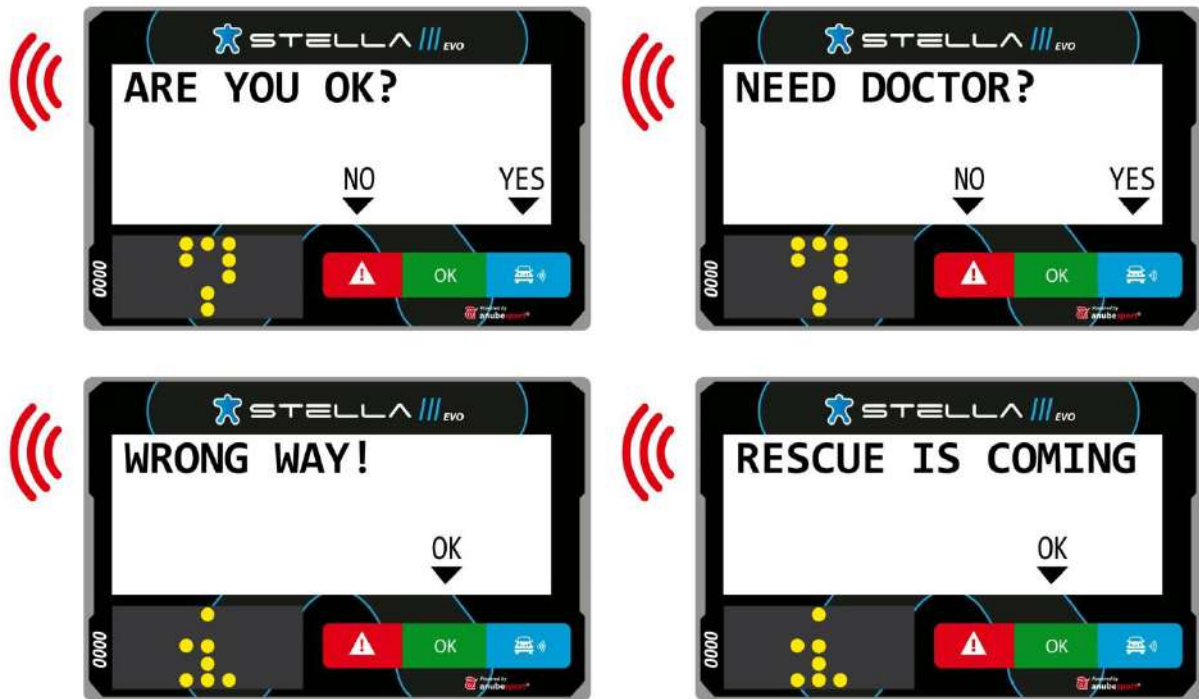

WAYPOINTS LIST



TOTAL ODOMETER RESET TO ZERO



OK

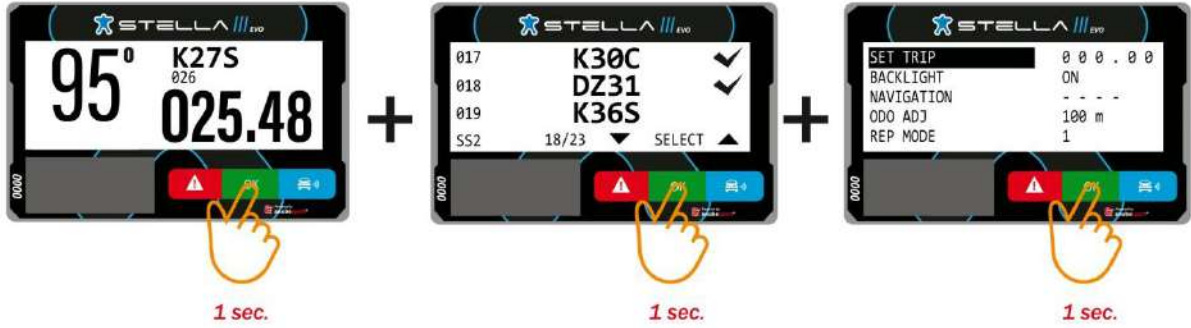

pending MNASZ ak.

Appendix 6 GPS Tracking System's Installation Kit

KIT COMPONENTS 80 €



1. Iridium Antenna
2. Power Cord
3. RF Cord
4. RF Antenna
5. Base/Mount
6. GPS Antenna
7. Adhesive
8. Straps
9. User Manual

IMPORTANT

For the functional tests and verification, all vehicles must have gone through the installation of the mount, power cord, and antennas.

1. POWER CORD

- Connect the red wire to the positive end of the battery 12V(+), and the grey wire to the negative end (GRD). The power cord must be connected directly to the battery (without interruptions and without contact in the power supply).
- A 3A fuse (not included) should be connected to the red wire.
- Take the cord to the location in which the STELLA III EVO is to be installed. All other wires must be insulated, they cannot touch.



2. BASE/MOUNT

- Motorcycles and ATV: The mount can be attached to the handle bar or to a metal plaque close to the navigation system.
- Cars and UTV: The mount can be attached to the panel, or to the roll cage bars. STELLA III EVO buttons must be visible and accessible to the participant (pilot/navigator) even when they are sitting and with the seatbelts buckled.

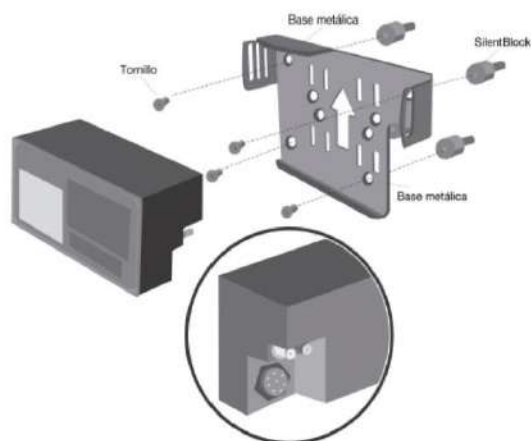

IMPORTANT

Leave the cords (antenna and battery) in place with at least 10 cm to spare for easy handling.
At least 5 cm of space behind the mount (bottom right corner) to allow space for power cord/connections.

3. GPS ANTENNA

The GPS antenna must be installed horizontally and without obstructions toward the sky. In cars and UTV, It can be mounted on the roof, the hood, or the dashboard. In motorcycles and ATV, attach to the mudguard. For additional firmness, it is recommended to cover it with adhesive tape (non metallic when mounting it to a metallic surface) and pull-up (when attached to soft or plastic parts).



4. ANTENNA IRIDIUM

The Iridium antenna must be installed horizontally and without obstructions toward the sky. In cars and UTV, It can be mounted on the roof, the hood, or the dashboard. In motorcycles and ATV, attach to the mudguard. For additional firmness, it is recommended to cover it with adhesive tape (non metallic when mounting it to a metallic surface) and pull-up (when attached to soft or plastic parts).



5. RF ANTENNA

The radio-frequency antenna must be installed vertically to the roll cage bars (cars and UTV) and the forks (motorcycles and ATV). It is mandatory to use separators (included in the kit) to avoid contact with metallic parts and the carbon fibre that surrounds it.

Once the antennas are mounted, take the SMA connection cords to the base/mount where the STELLA III EVO will be installed.



Appendix 7 Items at the organisers' discretion

After the Prize Giving Ceremony, we are delighted to announce that a jubilee party will be held in celebration of the XX-th Hungarian Baja, and we warmly invite everyone to join us. We kindly recommend making accommodation arrangements accordingly.

We wish everyone a safe and accident-free competition!

pending MNASZ approval